

HAC501

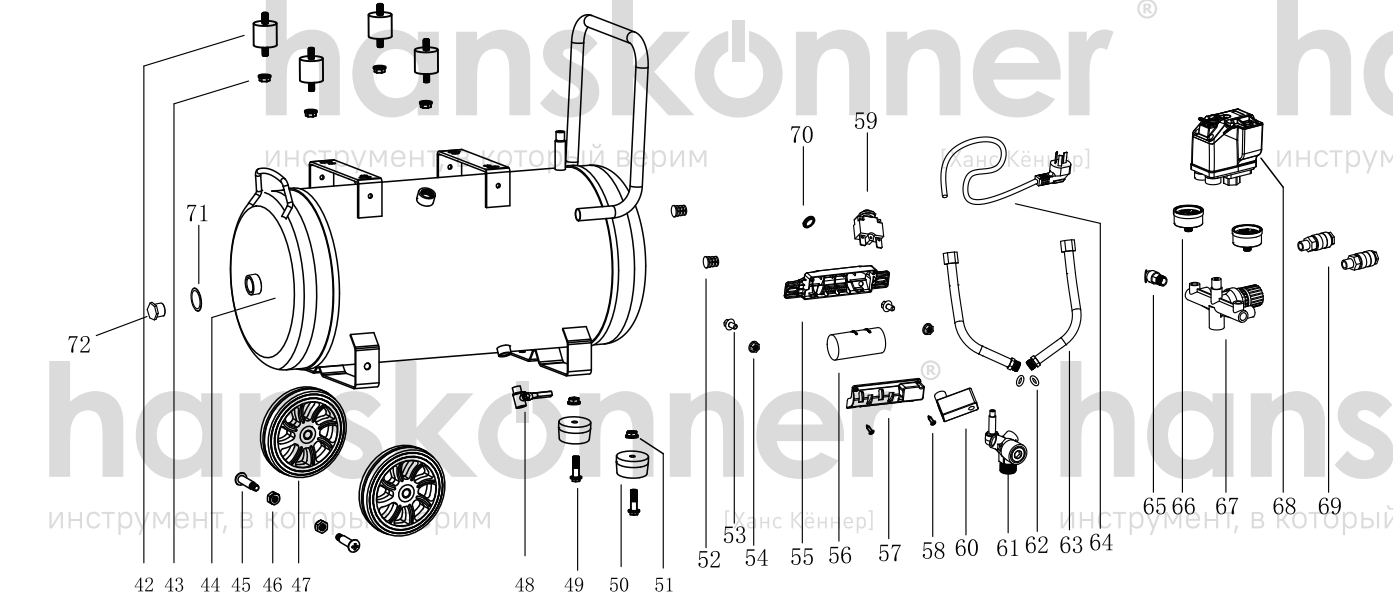
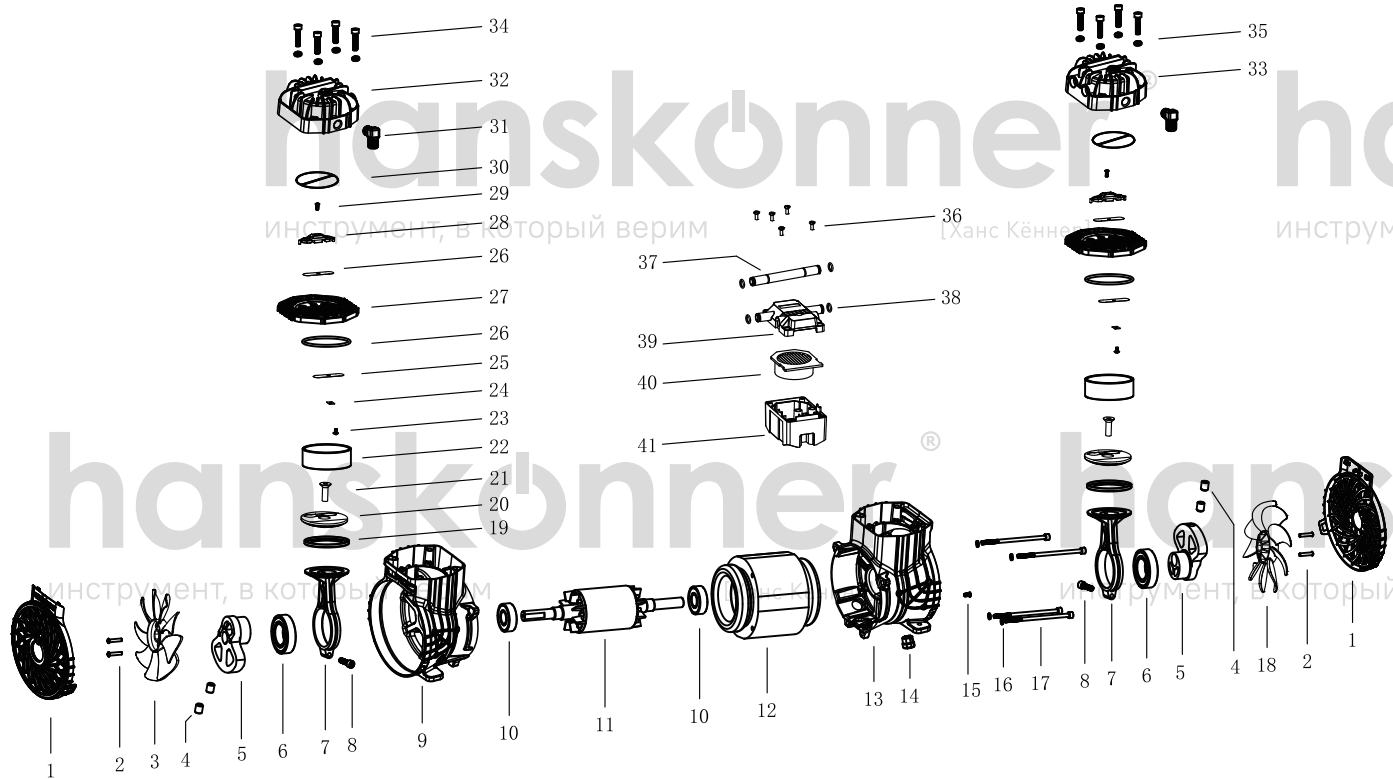

No.	Description	No.	Description
1	Fan Cover	37	Silencer aluminum tube
2	Screw	38	Silencer aluminum tube O ring
3	Right Fan	39	Upper cover of Silencer
4	Screw	40	Air filter element
5	Crank	41	Silencer chamber
6	Bearing 6006	42	Shock pad
7	Connecting Rod	43	Nut
8	Screw	44	Air tank
9	Left Crank Case	45	Axle
10	Bearing 6203	46	Nut
11	Rotor	47	Wheels
12	Stator	48	Drain Valve
13	Right Crank Case	49	Bolt
14	Strain Relief Bushing	50	Foot Pad
15	Screw	51	Nut
16	Spring Washer	52	Rod Plug
17	Screw	53	Bolt
18	Left Fan	54	Nut
19	Piston Ring	55	Capacitor Box Top Cover
20	Pressure plate	56	Capacitor
21	Screw	57	Capacitor Box Bottom Cover
22	Cylinder	58	Screw
23	Screw	59	Overload Protector
24	Intake Valve Plate Pressing Block	60	Solenoid Valve
25	Air Valve	61	Check valve
26	Cylinder O Ring	62	High pressure Pipe O-ring
27	Valve Plate	63	High pressure Pipe
28	Limit block	64	Power Cord & plug
29	Screw	65	Safety Valve
30	Cylinder Cover O Ring	66	Pressure Gauge
31	Elbow	67	Pressure Regulator
32	Left Cylinder Cover	68	Pressure Switch
33	Right Cylinder Cover	69	quick connector
34	Screw	70	Overload Protector Washer
35	Spring Washer	71	O Ring
36	Screw	72	Plug

HAC501-EX-25AL003K